

Installation Instructions

devireg® 316

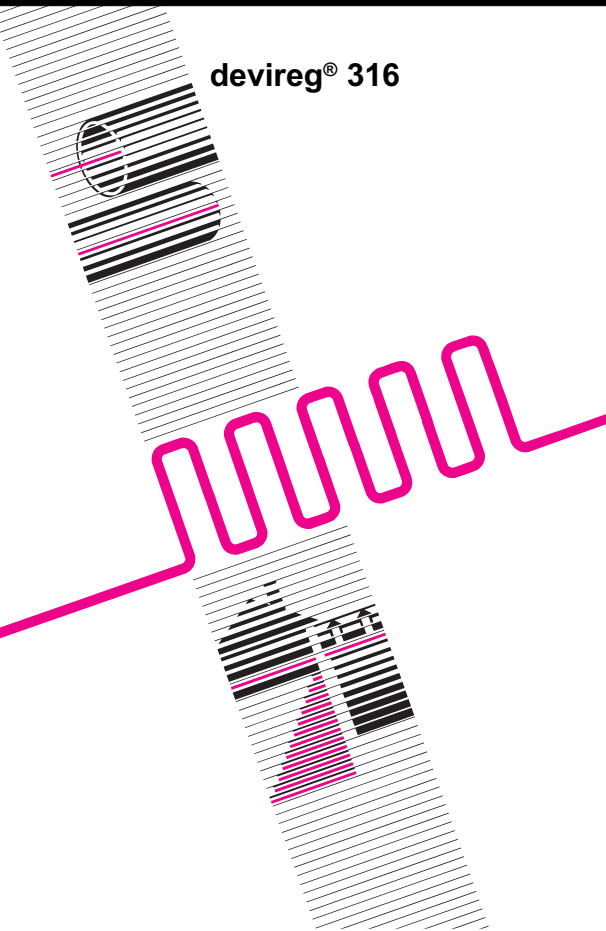

DEVI 

devireg® 316 is a thermostat for DIN rail attachment and has a height of 52 mm. **devireg® 316** is applied for control of room temperature, floor temperature, ventilation, cooling or as thermostat used for control of heat in gutters, etc.

Installation:

The installation must be permanent (**devireg® 316** must be placed after the switch). The sensing unit can be extended up to 50 m with 1.5 mm² installation cable without affecting the accuracy of the thermostat.

Never place the sensing unit parallel to high-voltage cables, as undesirable signals may be induced.

Night set-back (☾):

By bridging clamps 4 and 6 via an external clock, e.g.

devitime 301, the thermostat can be set to reduce the temperature at night (adjustable between 0°C to +8°C).

Hysteresis (Diff):

It is possible to adjust the hysteresis between 0,2°C and 6°C. If the temperature is set at 18°C and the hysteresis at 3°C the thermostat will switch on at 18°C and off at 21°C.

Difference (Diff):

The heating system is connected when the reference temperature is between the regulated maximum and minimum temperature values. See description of temperature regulation II. When the temperature falls below the set value the thermostat relay is activated and the yellow light goes on.

When the temperature goes above the max. regulation the relay is disconnected and both lights go off.

Galvanic separation:

The thermostat is designed so that the sensor circuit is separated galvanically from the high current part, which means that the sensor part is regarded as a low current part.

Note!!!

When **devireg® 316** is used as a gutter thermostat there must be a connection between clamps 9 and 10. The outdoor sensor must be mounted thus it is not exposed to direct sunlight.

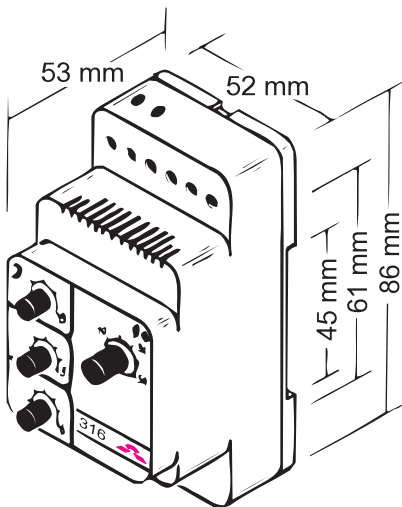

Fig. 1

Temperature regulation I:

In this case the thermostat is to be applied in connection with heating systems or refrigerating systems. The requested temperature is regulated in the scale with temperatures from -10°C to $+50^{\circ}\text{C}$. Check that the hysteresis (Diff) is adjusted to what is requested (hysteresis at 1°C is recommended for control of room temperature).

Temperature regulation II:

In this case the thermostat is to be used as a difference thermostat for regulation of snow and ice melting systems. The range of the thermostat is decided by adjusting the temperature range -10°C to $+50^{\circ}\text{C}$ (requested max. temperature) and the temperature range -10°C to $+5^{\circ}\text{C}$ (requested min. temperature). If the heating system has to be connected when the temperatures are between $+5^{\circ}\text{C}$ to -5°C the min. temperature is set to -5°C and the max. temperature to $+5^{\circ}\text{C}$.

Cooling:

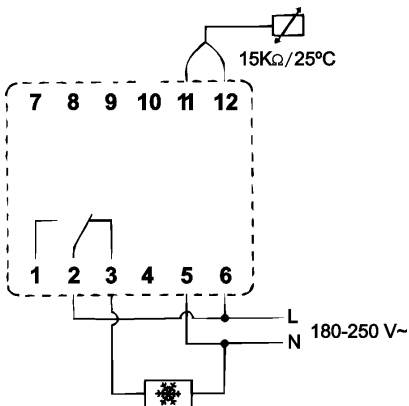

Heating:

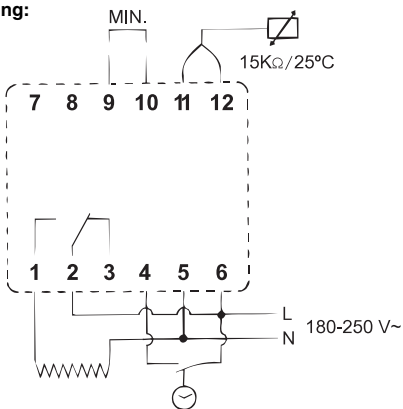

Trouble-shooting

Control of functioning:

If heat is not turned on by activating the thermostat, check the RCD and fuses before contacting an authorized electrician.

Trouble-shooting chart:

Reserved for the electrician!

Control of functioning:

- Control mains voltage on clamps 5 and 6.
- Tighten up load clamps 1 to 3.
- Measure the resistance in the heating cable and calculate the output:

$$P = \frac{U^2}{R} = \frac{52900}{R} \text{ W (at 230 V)}$$

From the calculated output the heating cable type can be determined by looking it up in your • catalogue.

- If sensor wire clamps no. 11 and 12 are removed the red indicator lamp should light up and the thermostat should switch on. If not the thermostat is defect.
- Measuring of sensor with ohmmeter should give a stable resistance compared to the ambient temperature - see technical data chart.
- If the sensor access is short-circuited the indicator should turn off and the thermostat should be switched off. If not, the thermostat is defect.
- When the mains voltage is disconnected the relay contact must be open.

Technical data

Temperature range:	-10°C to +50°C
Working temperature:	-10°C to +50°C
Voltage:	180 - 250 V ~ 50 Hz
Breaking power:	16 A
Night set-back adjustable:	0.2°C - 8°C
Differens adjustable:	0.2°C - 6°C
Cap class:	IP 20
Regulation: range I range II	-10°C to +50°C -10°C to +5°C
Sensor type:	NTC 15 kOhm at 25°C
Sensing value:	-10°C 66 kOhm 0°C 42 kOhm +25°C 15 kOhm +50°C 6 kOhm

The DEVI Warranty:

You have purchased a deviheat® system, which we are certain will increase your home comfort and economy.

deviheat® provides complete heating solutions with deviflex® heating cables or devimat® heating mats, devireg® thermostats and devifast fitting bands.

If, however, contrary to all expectations, a problem should occur with your heating system, we at DEVI, with manufacturing units in Denmark, are, as European Union suppliers, subject to general product liability rules, as stated in Directive 85/374/CEE, and all relevant national laws which implies that: DEVI provides a warranty for deviflex® heating cables and devimat® heating mats for a 10 year period and all other DEVI products for a 2 year period against defects in material and production.

The guarantee is granted on the conditions that the WARRANTY CERTIFICATE on the overleaf is filled out properly in accordance to instructions and that the defect is inspected by, or presented to, DEVI or authorised DEVI distributor.

Please note, that the wording of the WARRANTY CERTIFICATE must be provided in english or local language with the ISO code for your country in the upper left corner of the

front page of the installation instruction in order to release the warranty.

The obligation of DEVI will be to repair or supply a new unit, free of charge to the customer, without secondary charges linked to repairing the unit. In case of defective devireg® thermostats, DEVI reserves the right to repair the unit free of charge and without unreasonable delay to the customer.

The DEVI warranty only covers connections made by authorised electricians and installations performed in accordance with the installation instruction, and does not cover faults caused by incorrect designs supplied by others, misuse, damage caused by others, or incorrect installation or any subsequent damage, that may occur. If DEVI is required to inspect or repair any defects caused by any of the above, then all work will be fully chargeable.

The DEVI warranty is void, if payment of the equipment is in default.

At all times, we at DEVI will respond honestly, efficiently and promptly to all queries and reasonable requests from our customers.

The above mentioned warranty concerns product liability whereas matters in relation to legislation on sale of goods shall be referred to national law.

Warranty Certificate

The DEVI Warranty is granted to:

Name:

Address:

Postal code:

Phone:

Please Observe!

In order to obtain the DEVI Warranty, the following must be carefully filled in. See other conditions on the overleaf.

Electrical Installation by:

Installation date:

Type of thermostat:

Production code:

Suppliers Stamp:

DE-VI
DK · 7100 Vejle
Phone +45 76 42 47 00
Fax +45 76 42 47 03



08095512 · 02.02